

Model 73028

MMCX Jack Right-Angle PCB Receptacle

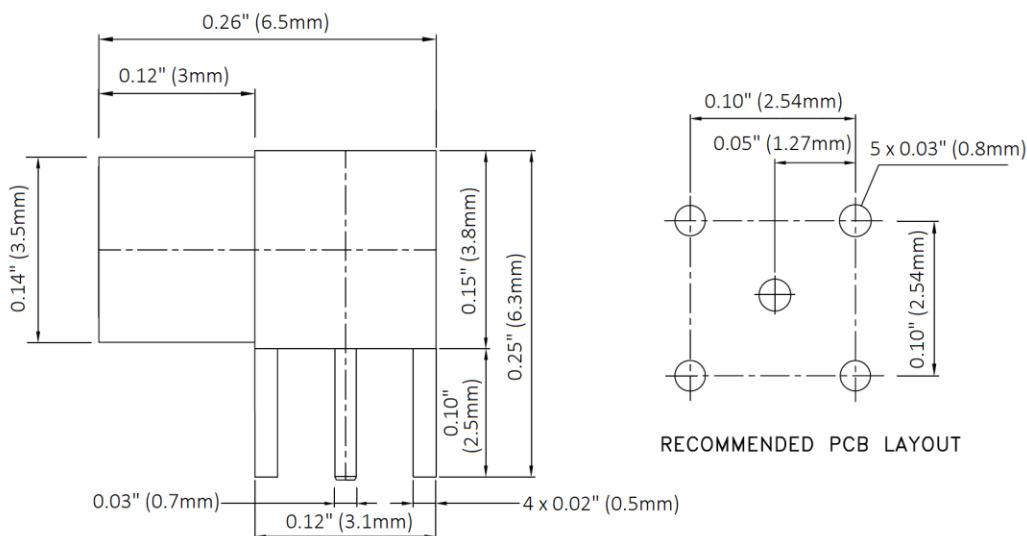

Features

- DC – 6 GHz
- Small size and durability for mobile communications
- Precision machined and gold-plated for low loss

Materials

Body:	Brass, Gold Plated
Center Contact:	Beryllium Copper, Gold Plated
Insulator:	PTFE

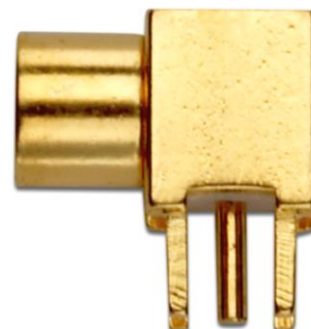

Ratings

Impedance	50 Ω
Frequency Range	DC – 6 GHz
Working Voltage	170 Vrms max.
Dielectric Withstanding Voltage	500 Vrms max.
VSWR	1.25 max.
Contact Resistance	5 mΩ max. (center contact); 2.5 mΩ max. (outer contact)
Insulation Resistance	1000 MΩ max.
Insertions	500

Ordering Information

Model: 73028

USA: Sales: 800-490-2361
 Technical Support: technicalsupport@pomonatest.com
 Fax: 425-446-5844

Europe: 31-(0) 40 2675 150 **International:** 425-446-5500

Where to Buy: www.pomonaelectronics.com

All dimensions are in inches. Tolerances (except noted): .xx = ±.02" (.51 mm), .xxx = ±.005" (.127 mm). All specifications are to the latest revisions. Specifications are subject to change without notice. Registered trademarks are the property of their respective companies.